



Shanghai Minyue
Semiconductors Co.,Ltd
Tel:0086-21-57159233
Fax:0086-21-60415325

SF11 Thru SF18

Features

- Fast Switching Speed
- Marking : Type Number
- Lead Free Finish/RoHS Compliant (Note1) ("P" Suffix designates Compliant. See ordering information)
- Epoxy meets UL 94 V-0 flammability rating
- Moisture Sensitivity Level 1

Maximum Ratings

- Operating Temperature: -55°C to +125°C
- Storage Temperature: -55°C to +150°C
- Typical Thermal Resistance: 50.0°C/W Junction To Ambient

Part Number	Maximum Recurrent Peak Reverse Voltage	Maximum RMS Voltage	Maximum DC Blocking Voltage
SF11	50V	35V	50V
SF12	100V	70V	100V
SF13	150V	105V	150V
SF14	200V	140V	200V
SF15	300V	210V	300V
SF16	400V	280V	400V
SF18	600V	420V	600V

1.0 Amp Super Fast Recovery Rectifiers 50 to 600 Volts

DO-41

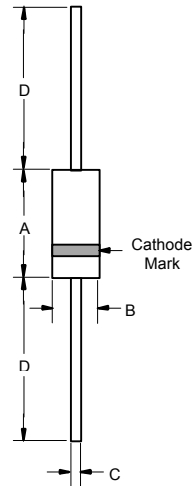

Electrical Characteristics @ 25°C Unless Otherwise Specified

Average Forward Current	$I_{F(AV)}$	1.0A	$T_A = 55^\circ\text{C}$
Peak Forward Surge Current	I_{FSM}	30.0A	8.3ms, half sine
Maximum Instantaneous Forward Voltage SF11-SF14 SF15-SF16 SF18	V_F	0.95V 1.30V 1.70V	$I_{FM} = 1.0A$
Maximum DC Reverse Current At Rated DC Blocking Voltage	I_R	5.0uA 100uA	$T_A = 25^\circ\text{C}$ $T_A = 100^\circ\text{C}$
Maximum Reverse Recovery Time	T_{RR}	35.0nS	$I_F=0.5A, I_R=1.0A,$ $I_{RR}=0.25A$
Typical Junction Capacitance SF11-SF14 SF15-SF18	C_J	40pF 25pF	Measured at 1.0MHz, $V_R=4.0V$

DIM	DIMENSIONS				NOTE
	INCHES		MM		
	MIN	MAX	MIN	MAX	
A	.166	.205	4.10	5.20	
B	.080	.107	2.00	2.70	
C	.028	.034	.70	.90	
D	1.000	---	25.40	---	

Note: 1. High Temperature Solder Exemption Applied, see EU Directive Annex 7.

SF11 thru SF18

Figure 1
Reverse Recovery Time Characteristic And Test Circuit Diagram

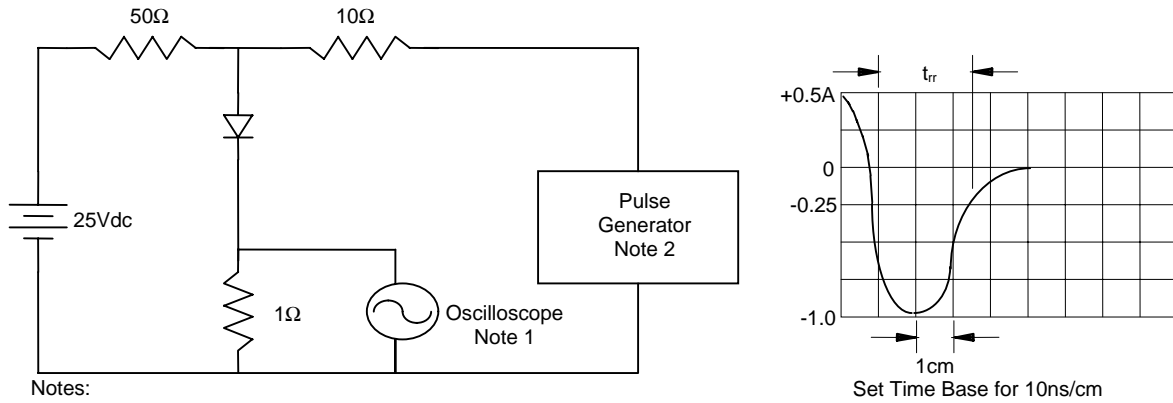

- Notes:
1. Rise Time = 7ns max.
Input impedance = 1 megohm, 22pF
 2. Rise Time = 10ns max.
Source impedance = 50 ohms
 3. Resistors are non-inductive

Figure 2
Peak Forward Surge Current

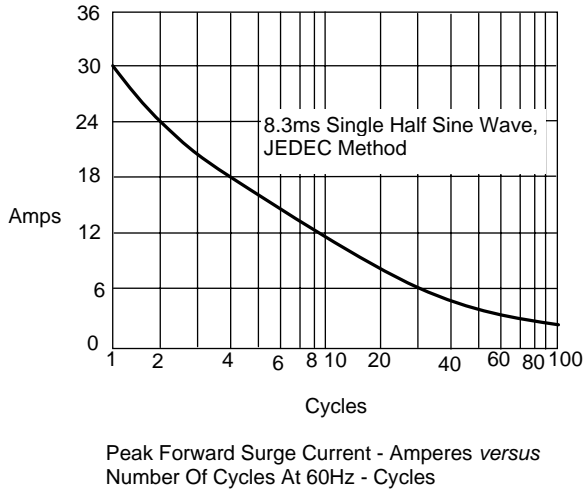
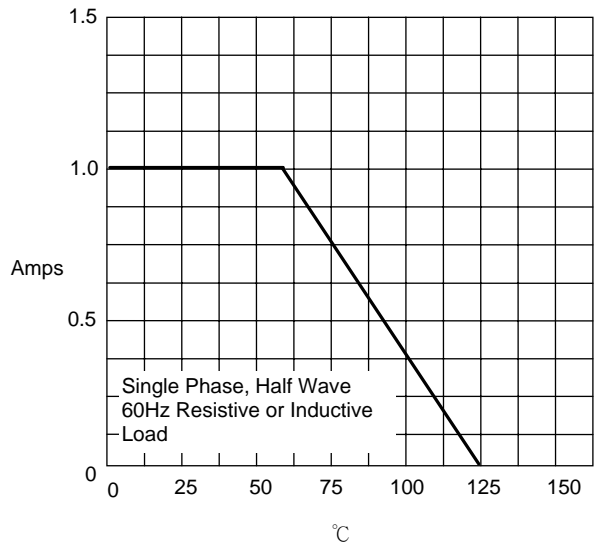

Figure 3
Maximum Average Forward Current Rating



Average Forward Rectified Current Per Leg - Amperes versus Ambient Temperature - °C

SF11 thru SF18

Figure 4
Typical Junction Characteristics

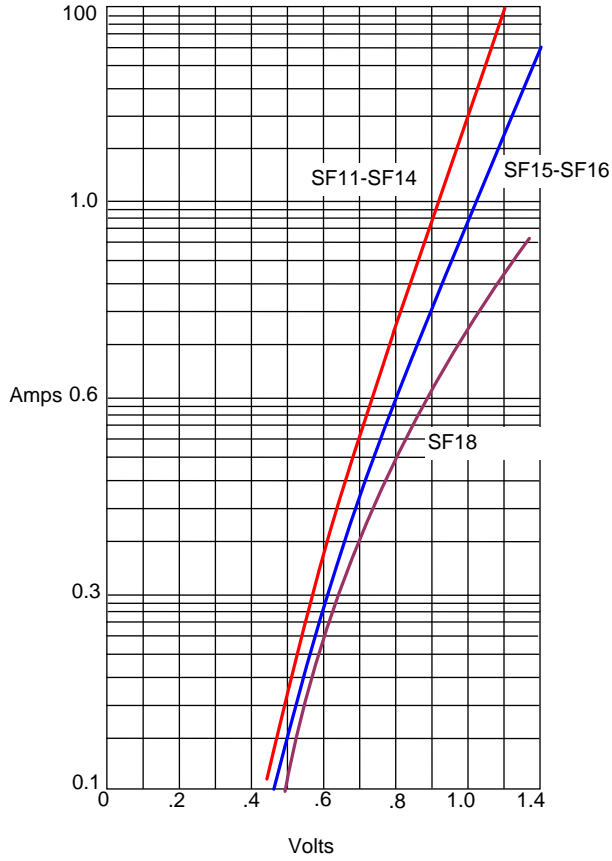

Instantaneous Forward Current - Amperes versus
Instantaneous Forward Voltage - Volts

Figure 5
Typical Reverse Characteristics

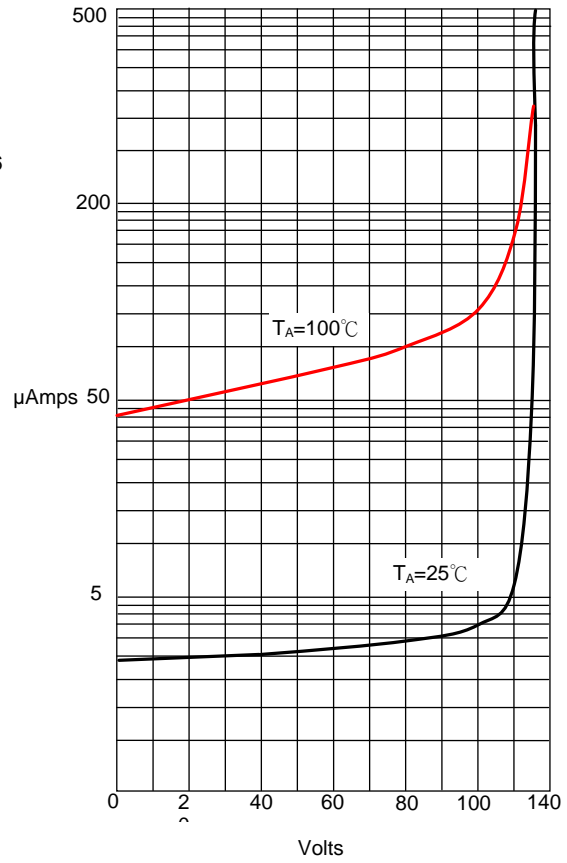

Instantaneous Reverse Leakage Current - MicroAmperes versus
Percent Of Rated Peak Reverse Voltage - %Volts

Figure 6
Typical Junction Characteristics

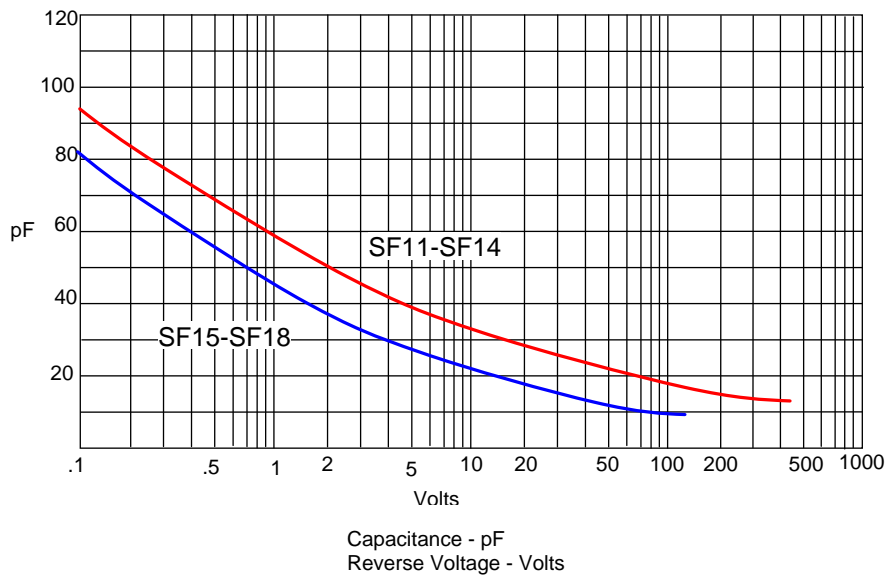

Capacitance - pF
Reverse Voltage - Volts