



Shanghai Miyue
Semiconductors Co.,Ltd
Tel:0086-21-57159233
Fax:0086-21-60415325

ESDA6V1L

Features

- Dual Transil Array For ESD Protection
- 2 Unidirectional Transil Functions
- Low leakageCurrent: $I_{Rmax} < 20 \mu A$ at V_{WM}
- 300W peak pulse power (8/20 us)
Epoxy meets UL 94 V-0 flammability rating
Moisture Sensitivity Level 1

6.1Volts ESD Protection Device

Maximum Ratings

Parameter	Symbol	Limits	unit
Electrostatic discharge MIL STD 883C-Method 3015-6 IEC61000-4-2 air discharge IEC61000-4-2 contact discharge	V_{PP}	25 16 9	KV KV KV
Peak pulse power 8/20us	P_{PP}	300	W
Junction temperature	T_j	150	°C
Storage temperature range	T_{stg}	-55~+150	°C
Maximum lead temperature For soldering during 10s	T_L	260	°C

SOT-23

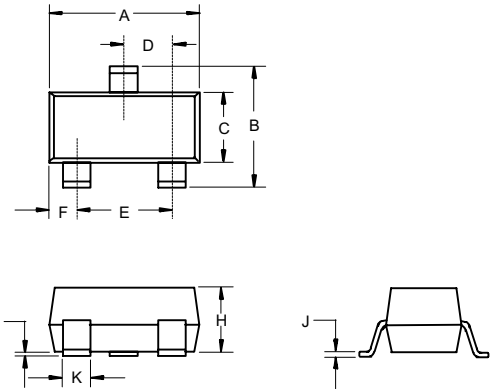

DIM	INCHES		MM		NOTE
	MIN	MAX	MIN	MAX	
A	.110	.120	2.80	3.04	
B	.083	.104	2.10	2.64	
C	.047	.055	1.20	1.40	
D	.035	.041	.89	1.03	
E	.070	.081	1.78	2.05	
F	.018	.024	.45	.60	
G	.0005	.0039	.013	.100	
H	.035	.044	.89	1.12	
J	.003	.007	.085	.180	
K	.015	.020	.37	.51	

Pin Configuration-Top View

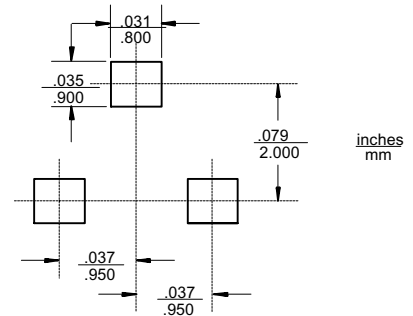
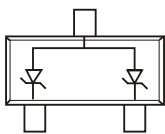

ESDA6V1L



ELECTRICAL CHARACTERISTICS ($T_A = 25^\circ\text{C}$ unless otherwise noted)

Symbol	Parameter
V_{WM}	Stand-off voltage
V_{BR}	Breakdown voltage
V_{CL}	Clamping voltage
I_{RM}	Leakage current
I_{PP}	Peak pulse current
αT	Voltage temperature coefficient
C	Capacitance
R_d	Dynamic resistance
V_F	Forward voltage drop

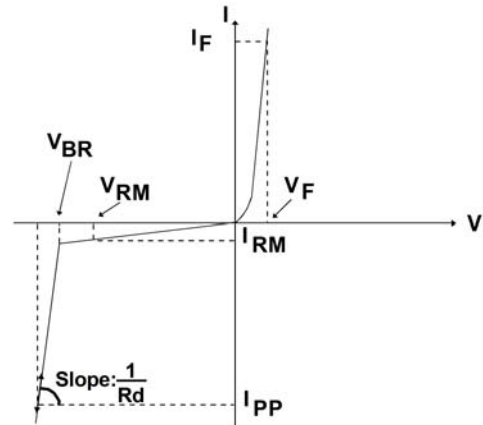

Parameter	Test Conditions	Symbol	Min	Typ	Max	Unit
Breakdown voltage	$I_R=1.0\text{mA}$	V_{BR}	6.1	6.65	7.2	V
Leakage current	$V_{WM}=5.25\text{V}$	I_R	-	-	20	μA
Capacitance	0V bias	C	-	140	-	pF
Forward voltage drop	$I_F=200\text{mA}$	V_F	-	-	1.25	V

ESDA6V1L



TYPICAL CHARACTERISTICS

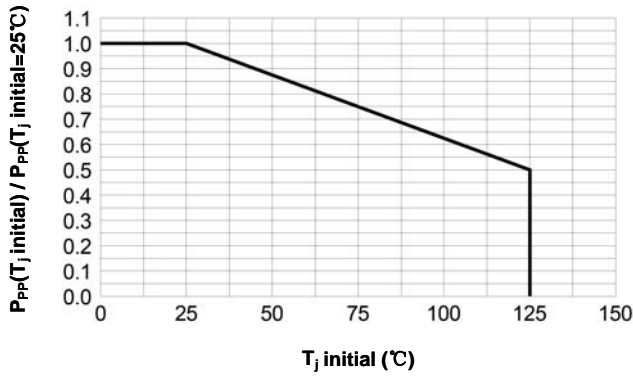

Fig.1: Peak power dissipation vs. initial junction temperature

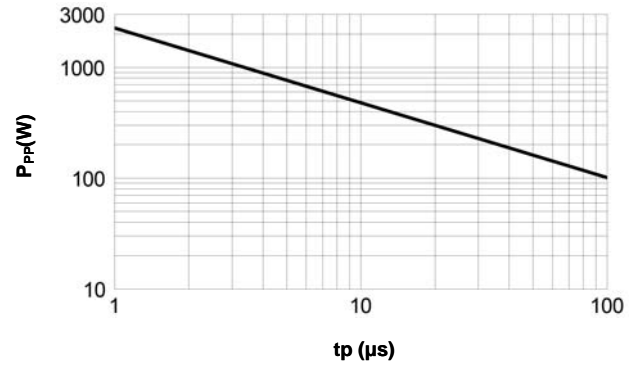

Fig.2: Peak pulse power vs. exponential pulse duration (T_{j initial} = 25°C)

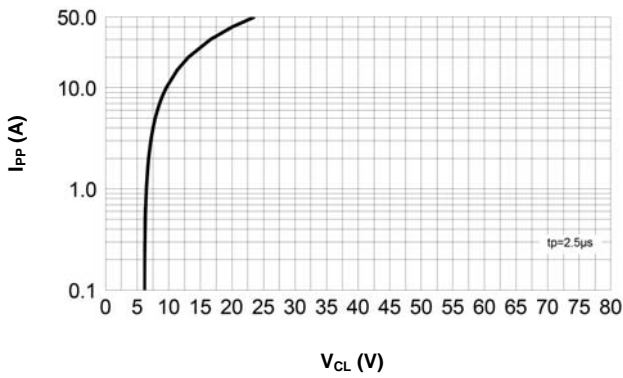

Fig.3: Clamping voltage vs. peak pulse current (T_{j initial} = 25°C, rectangular waveform tp = 2.5μs)

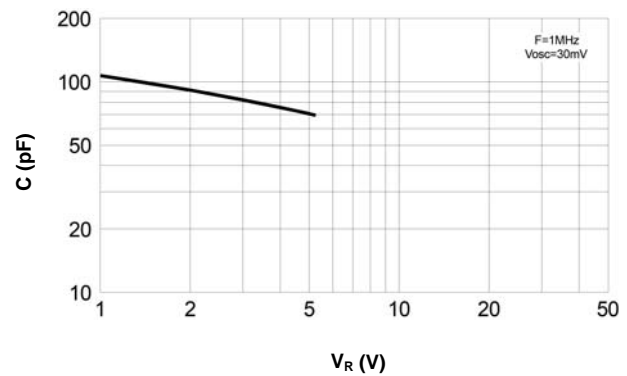

Fig.4: Capacitance vs. reverse applied voltage (typical values)

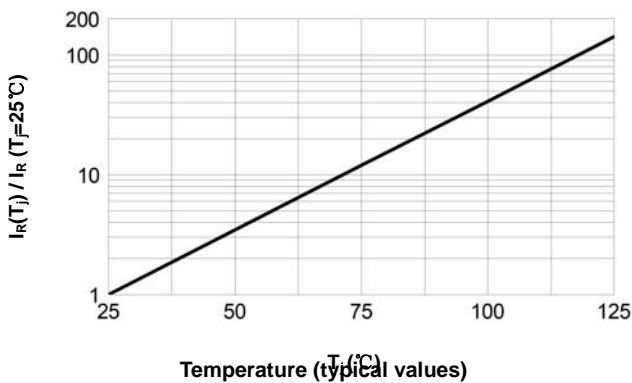

Fig.5: Relative variation of leakage current vs. junction temperature (typical values)

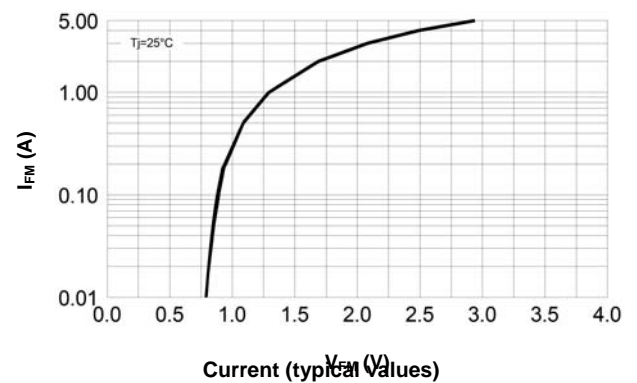

Fig.6: Peak forward voltage drop vs. peak forward current (typical values)