



Shanghai Minyue
Semiconductors Co.,Ltd
Tel:0086-21-57159233
Fax:0086-21-60415325

ESD5V0D3 Thru ESD12VD3

Features

- For sensitive ESD protection
- Excellent clamping capability
- Low leakage
- ESD rating of class 3(>16KV)per Human Body Mode
- For space saving application
- Fast response ,response time less than 1ns.
Epoxy meets UL 94 V-0 flammability rating
Moisture Sensitivity Level 1

Maximum Ratings

- Operating Junction &StorageTemperature: -55°C to +150°C
- Maximum Thermal Resistance: 625°C/W Junction To Ambient

Parameter	Symbol	Limits	unit
IEC61000-4-2(ESD) Air Contact		±15 ±8	KV
ESD Voltage per human body mode		30	KV
Power Dissipation	Pd	200	mw

5V~12Volts ESD Protection Devices

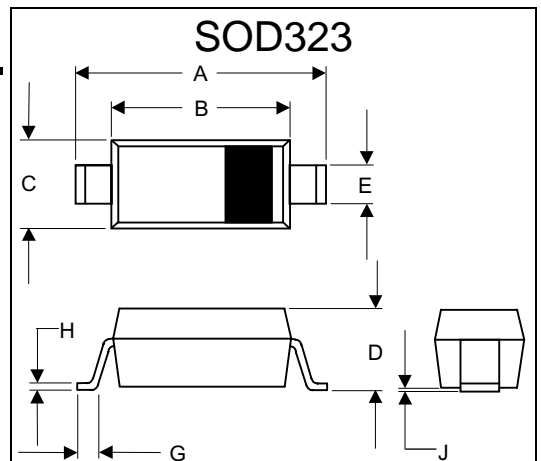

DIM	INCHES		MM		NOTE
	MIN	MAX	MIN	MAX	
A	.090	.107	2.30	2.70	
B	.063	.071	1.60	1.80	
C	.045	.053	1.15	1.35	
D	.031	.045	0.80	1.15	
E	.010	.016	0.25	0.40	
G	.004	.018	0.10	0.45	
H	.004	.010	0.10	0.25	
J	-----	.006	-----	0.15	

SUGGESTED SOLDER PAD LAYOUT

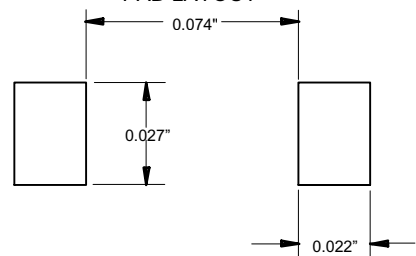

ELECTRICAL CHARACTERISTICS ($T_A = 25^\circ\text{C}$ unless otherwise noted)

Symbol	Parameter
I_{PP}	Maximum Reverse Peak Pulse Current
V_C	Clamping Voltage @ I_{PP}
V_{RWM}	Working Peak Reverse Voltage
I_R	Maximum Reverse Leakage Current @ V_{RWM}
V_{BR}	Breakdown Voltage @ I_T
I_T	Test Current
I_F	Forward Current
V_F	Forward Voltage @ I_F
P_{pk}	Peak Power Dissipation
C	Max. Capacitance @ $V_R=0$ and $f=1\text{MHz}$

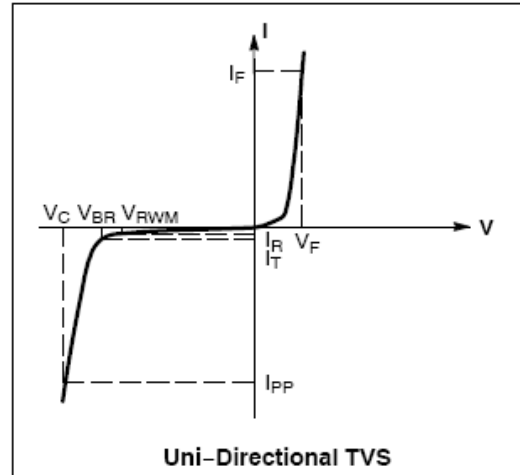

ELECTRICAL CHARACTERISTICS ($T_A = 25^\circ\text{C}$ unless otherwise noted, $V_F = 0.9\text{ V Max.}$ @ $I_F = 10\text{mA}$ for all types)

Device	Device Marking	V_{RWM}	$I_R (\mu\text{A})$	$V_{BR} (\text{V})$		I_T	V_C	$I_{PP} (\text{A})^+$	$V_C (\text{V})$	P_{pk}^+	C
		(V)	@ V_{RWM}	@ I_T (Note 2)	@ I_T (Note 2)		@ $I_{PP} = 5\text{ A}$		(V)		
		Max	Max	Min	Max	mA	V	Max	Max	Max	Typ
ESD5V0D3	ZA	5.0	1.0	6.2	7.3	1.0	9.8	15	15.5	350	350
ESD12VD3	ZC	12	1.0	13.3	15.75	1.0	22	12	33	350	150

+Surge current waveform per Figure 6.

2. V_{BR} is measured with a pulse test current I_T at an ambient temperature of 25°C .

TYPICAL CHARACTERISTICS

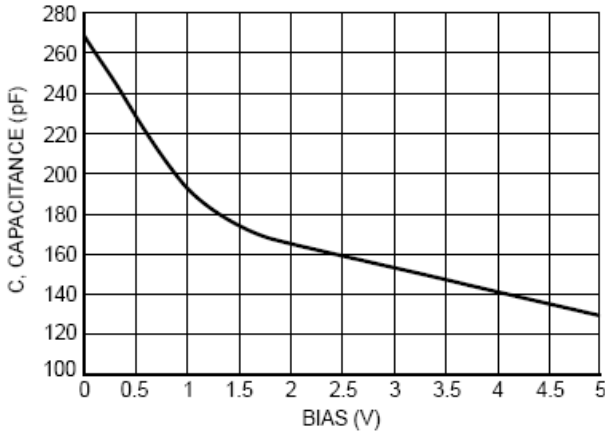

Figure 1. SD05 Typical Capacitance versus Bias Voltage

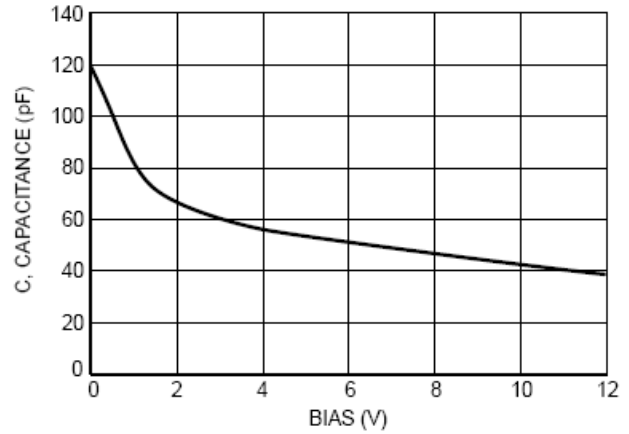

Figure 2. SD12 Typical Capacitance versus Bias Voltage

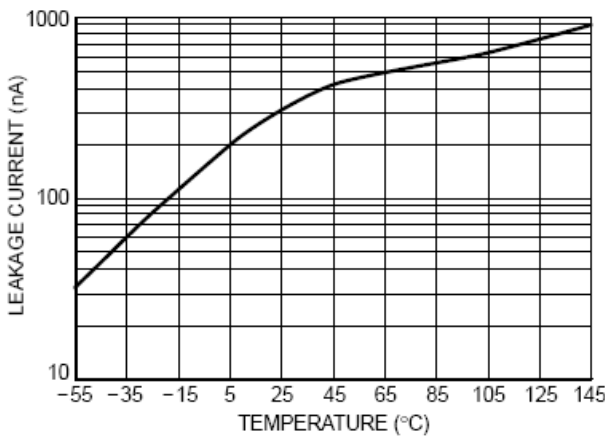

Figure 3. SD05 Typical Leakage Current versus Temperature

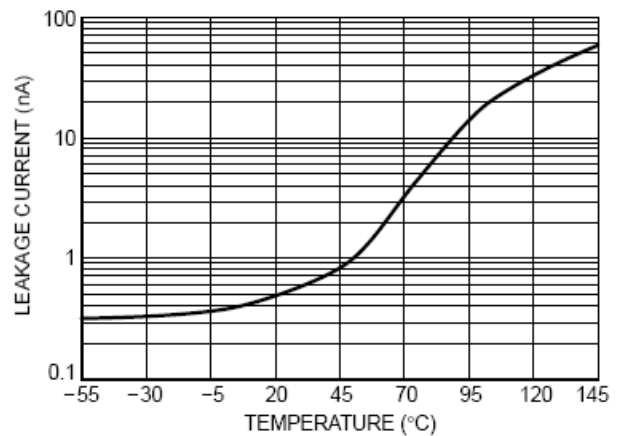

Figure 4. SD12 Typical Leakage Current versus Temperature

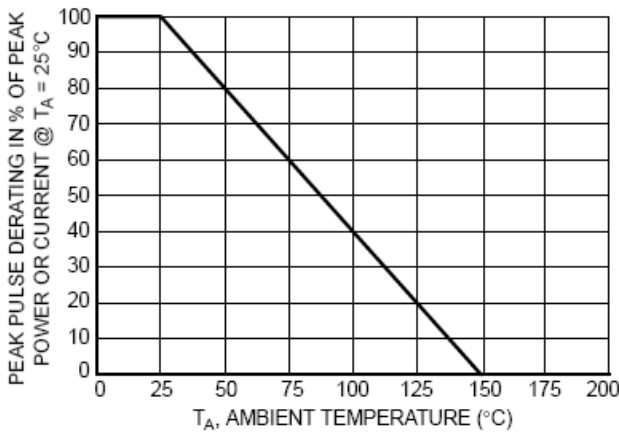

Figure 5. Pulse Derating Curve

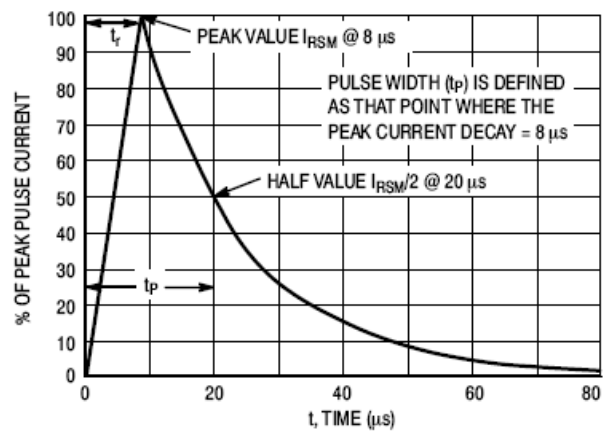

Figure 6. 8 × 20 μs Pulse Waveform